

# **UNIFIED FACILITIES CRITERIA (UFC)**

---

## **SANITARY AND INDUSTRIAL WASTEWATER COLLECTION: GRAVITY SEWERS AND APPURTENANCES**



APPROVED FOR PUBLIC RELEASE; DISTRIBUTION UNLIMITED

**UNIFIED FACILITIES CRITERIA (UFC)**

**SANITARY AND INDUSTRIAL WASTEWATER COLLECTION: GRAVITY SEWERS  
AND APPURTENANCES**

Any copyrighted material included in this UFC is identified at its point of use.  
Use of the copyrighted material apart from this UFC must have the permission of the  
copyright holder.

U.S. ARMY CORPS OF ENGINEERS (Preparing Activity)

NAVAL FACILITIES ENGINEERING COMMAND

AIR FORCE CIVIL ENGINEER SUPPORT AGENCY

Record of Changes (changes are indicated by \1\ ... /1/)

Change No.	Date	Location

---

This UFC supersedes TM 5-814-1, dated 4 March 1985. The format of this UFC does not conform to UFC 1-300-01; however, the format will be adjusted to conform at the next revision. The body of this UFC is the previous TM 5-814-1, dated 4 March 1985.

## FOREWORD

\1\

The Unified Facilities Criteria (UFC) system is prescribed by MIL-STD 3007 and provides planning, design, construction, sustainment, restoration, and modernization criteria, and applies to the Military Departments, the Defense Agencies, and the DoD Field Activities in accordance with [USD\(AT&L\) Memorandum](#) dated 29 May 2002. UFC will be used for all DoD projects and work for other customers where appropriate. All construction outside of the United States is also governed by Status of forces Agreements (SOFA), Host Nation Funded Construction Agreements (HNFA), and in some instances, Bilateral Infrastructure Agreements (BIA.) Therefore, the acquisition team must ensure compliance with the more stringent of the UFC, the SOFA, the HNFA, and the BIA, as applicable.

UFC are living documents and will be periodically reviewed, updated, and made available to users as part of the Services' responsibility for providing technical criteria for military construction. Headquarters, U.S. Army Corps of Engineers (HQUSACE), Naval Facilities Engineering Command (NAVFAC), and Air Force Civil Engineer Support Agency (AFCEA) are responsible for administration of the UFC system. Defense agencies should contact the preparing service for document interpretation and improvements. Technical content of UFC is the responsibility of the cognizant DoD working group. Recommended changes with supporting rationale should be sent to the respective service proponent office by the following electronic form: [Criteria Change Request \(CCR\)](#). The form is also accessible from the Internet sites listed below.

UFC are effective upon issuance and are distributed only in electronic media from the following source:

- Whole Building Design Guide web site <http://dod.wbdg.org/>.

Hard copies of UFC printed from electronic media should be checked against the current electronic version prior to use to ensure that they are current.

### AUTHORIZED BY:

  
DONALD L. BASHAM, P.E.  
Chief, Engineering and Construction  
U.S. Army Corps of Engineers

  
DR. JAMES W. WRIGHT, P.E.  
Chief Engineer  
Naval Facilities Engineering Command

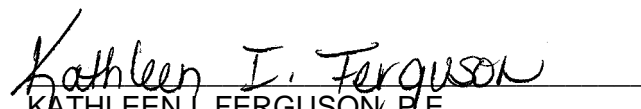
  
KATHLEEN I. FERGUSON, P.E.  
The Deputy Civil Engineer  
DCS/Installations & Logistics  
Department of the Air Force

  
Dr. GET W. MOY, P.E.  
Director, Installations Requirements and  
Management  
Office of the Deputy Under Secretary of Defense  
(Installations and Environment)

**ARMY TM 5-814-1**  
**AIR FORCE AFM 88-11, Volume 1**

---

**SANITARY AND INDUSTRIAL WASTEWATER COLLECTION—  
GRAVITY SEWERS AND APPURTENANCES**

---

**DEPARTMENTS OF THE ARMY, AND THE AIR FORCE**  
**MARCH 1985**

## REPRODUCTION AUTHORIZATION/RESTRICTIONS

This manual has been prepared by or for the Government and, except to the extent indicated below, is public property and not subject to copyright.

Copyrighted material included in the manual has been used with the knowledge and permission of the proprietors and is acknowledged as such at point of use. Anyone wishing to make further use of any copyrighted material, *by itself and apart from this text*, should seek necessary permission directly from the proprietors.

Reprints or republications of this manual should include a credit substantially as follows: "Joint Departments of the Army and Air Force, USA, Technical Manual TM 5-814-1/AFM 88-11, Volume 1, Sanitary and Industrial Wastewater Collection—Gravity Sewers and Appurtenances."

If the reprint or republication includes *copyrighted* material, the credit should also state: "Anyone wishing to make further use of copyrighted material, *by itself and apart from this text*, should seek necessary permission directly from the proprietors."

## SANITARY AND INDUSTRIAL WASTEWATER COLLECTION— GRAVITY SEWERS AND APPURTENANCES

		<i>Paragraph</i>	<i>Page</i>
CHAPTER	1. GENERAL		
	Purpose and scope . . . . .	1-1	1-1
	Design objectives . . . . .	1-2	1-1
	Limitations on use . . . . .	1-3	1-1
	Alternatives to gravity sewers . . . . .	1-4	1-1
	2. PRELIMINARY DESIGN CONSIDERATIONS		
	Existing conditions . . . . .	2-1	2-1
	Field investigations . . . . .	2-2	2-1
	Guidelines for sewer system layout . . . . .	2-3	2-1
	Protection of water supplies . . . . .	2-4	2-1
	3. HYDRAULIC DESIGN OF SEWERS		
	Quantity of wastewater . . . . .	3-1	3-1
	Gravity sewer design . . . . .	3-2	3-2
	Depressed sewers . . . . .	3-3	3-5
	Hydrogen sulfide in sewers . . . . .	3-4	3-6
	4. SEWER SYSTEM APPURTENANCES		
	Manholes . . . . .	4-1	4-1
	Building connections . . . . .	4-2	4-1
	Cleanouts . . . . .	4-3	4-1
	5. STRUCTURAL DESIGN OF SEWERS		
General . . . . .	5-1	5-1	
Loads on sewers . . . . .	5-2	5-1	
Supporting strength of sewers . . . . .	5-3	5-2	
Special designs . . . . .	5-4	5-4	
CHAPTER	6. SEWER PIPE MATERIALS, FITTINGS AND JOINTS		
	General . . . . .	6-1	6-1
	Ductile iron . . . . .	6-2	6-1
	Cast iron soil . . . . .	6-3	6-1
	Vitrified clay . . . . .	6-4	6-1
	Concrete . . . . .	6-5	6-2
	Asbestos-cement . . . . .	6-6	6-2
	Polyvinyl chloride (PVC) plastic . . . . .	6-7	6-2
	Acrylonitrile-butadiene-styrene (ABS) plastic . . . . .	6-8	6-2
	Reinforced plastic mortar (RPMP) . . . . .	6-9	6-3
	Special materials . . . . .	6-10	6-3
APPENDIX	A. REFERENCES		A-1
	B. EXAMPLE PROBLEMS		B-1
BIBLIOGRAPHY			BIBLIO-1
GLOSSARY			GLOSS-1
LIST OF FIGURES			
Figure	3-1.	Chart for Manning formula.	3-4
	3-2.	Hydraulic properties of circular sewers.	3-5
	5-1.	Trench load coefficient.	5-2
	5-2.	Load factors and class of bedding.	5-5
LIST OF TABLES			
Table	3-1.	Domestic wastewater allowances.	3-1
	5-1.	Surface load coefficient.	5-3
	5-2.	Impact factor vs. height of cover.	5-4

\*This manual supersedes TM 5-814-1/AFM 88-11, Volume 1, 1 September 1958.

## CHAPTER 1

### GENERAL

#### 1-1. Purpose and scope.

This manual provides information, instructions, procedures and criteria for the design of gravity sanitary and industrial wastewater collection systems for fixed Army and Air Force installations, and any applicable special projects.

#### 1-2. Design objectives.

The design of a gravity wastewater collection system must provide an engineered system of sewers, complete with all appurtenant facilities, sufficient in size, slope and capacity to collect and convey the required wastewater flows to an acceptable point of discharge. The system must be practicable, economically feasible, and must be located to minimize the costs of installation, operation and maintenance. Sewers and appurtenances must be structurally sound, and must protect the environment from pollution caused by leakage at pipe joints or manhole structures. Extraneous flows that hydraulically overload the system and produce flooding at sewer manholes and lift stations must be excluded. Elimination of excessive infiltration and inflow is essential in avoiding increased costs of sewer maintenance, wastewater pumping and treatment. Even more important in this regard is the necessity to maintain design wastewater treatment efficiencies, and thus assure that effluent discharge requirements are met. Contributing waste flows which are harmful to sewer pipe materials and appurtenant structures, toxic to biological and other waste treatment systems, or create fire and explosion hazards, must be identified and evaluated early during predesign, so that suitable materials and/or procedures for their disposal can be included.

#### 1-3. Limitations on use.

To protect sewers, pumping stations and treatment facilities from unwanted pollutants and extraneous flows that result in excessive operation and maintenance, fire and explosion hazards, or reduced wastewater treatment efficiencies, limitations must be placed on the use of the sewer system. Wastewaters from fuel loading and dispensing systems, grease and oil from vehicle wash racks, aircraft washing and garage or shop floor drains, must be directed through oil/water separators to prevent such wastes from entering the sewers. Combined sewers will not be permitted, and collection of storm drainage of any kind must be avoided. All types of industrial wastes must be analyzed to determine if any substance is detrimental to sewer

pipe materials, waste treatment processes, or creates a safety hazard to personnel. The general guidelines cited in Water Pollution Control Federation (WPCF) Manual of Practice No. 3 for identifying wastes not admissible to sewers will be followed closely. Chapters 3 and 8 of TM 5-814-8 provide a description of the various types of industrial wastes generated at military installations, and give criteria governing discharge to sanitary or industrial waste sewers.

#### 1-4. Alternatives to gravity sewers.

*a. Wastewater pumping.* There may be areas in which the topography is not well suited for construction of a gravity sewer system. In such areas, the installation of a gravity system would require deep and expensive trench excavation, jacking, boring, tunneling, or construction of long sewer lines to avoid unfavorable terrain. In cases like these, the existing topography and subsurface conditions at the site will be studied to determine if a pump or ejector station would be more feasible. Depths of gravity sewers greater than 15 to 20 feet are usually uneconomical. However, the operation and maintenance costs of a pumping station when capitalized, may offset or exceed the construction costs of a deep gravity sewer system. When it is not readily apparent which solution would be more economical, the decision to use one or the other will be based on a life cycle cost analysis. Initial capital and construction costs for pumps, ejectors, structures, force mains, etc., plus operation and maintenance costs, will be compared with the costs of deep trench excavation, or other special construction methods required for a gravity system. Generally, a gravity sewer system will be justified until its cost exceeds the cost of a pumped system by 10 percent. TM 5-814-8 contains criteria for economic evaluation of wastewater pumping. TM 5-814-2/AFM 88-11, Chapter 2 provides criteria for engineering and design of sanitary and industrial wastewater pumping facilities.

*b. Grinder pumps and vacuum systems.* Some areas under consideration may be further limited by high groundwater, unstable soil, shallow rock, or extremely adverse topography, and neither gravity sewers nor pump or ejector stations will be suitable. To overcome these difficulties, grinder pumps with small diameter (less than 4-inch) pressure sewers may be utilized. In a typical installation, wastewater from individual buildings will be discharged to a holding tank, and then periodically transferred by grinder pump through small diameter pipe, into either a central pressure main, conventional gravity sewer, pumping station, or

wastewater treatment facility. Vacuum systems offer an alternative to pressure sewers and may be used under similar circumstances. Both of these systems are relatively new and are continuously being improved. Manufacturers' literature should be carefully reviewed

along with operating data from existing installations before deciding to use either system. Design criteria for these types of installations are contained in TM 5-814-2/AFM 88-11, Chapter 2.

## CHAPTER 2

### PRELIMINARY DESIGN CONSIDERATIONS

#### 2-1. Existing conditions.

As an important initial step in the design process, existing maps, drawings, surveys, boring logs, and other data containing pertinent information on existing conditions in the area being sewered must be obtained. Possible sources of such information include the following:

- Installation or Facility Engineer.
- Army or Air Force using service.
- Federal Agencies such as United States Geological Survey and Soil Conservation Service.
- State, county or municipal engineering departments.
- Public utilities.
- Commercial businesses and private firms (including A/E).
- Regional or local planning boards.

#### 2-2. Field investigations.

If maps are not available, or do not provide satisfactory information or sufficient detail of the site, field surveys must be performed. Depending on the magnitude and complexity of the project, subsurface exploration with soil borings may be required. Topographic information should show locations of all streets, buildings, pavements, sidewalks, vegetation, drainage channels, and other land surface features such as utility manholes or structures, which may influence the design and layout of the collection system. Information on existing utilities should include the location of underground water lines, sanitary sewers, storm drains, gas mains, steam tunnels, electric conduits and similar facilities. For larger projects, the character of the soil in which sewers will be constructed should be determined. The presence of rock, unfavorable soil conditions, or high groundwater table should be clearly established.

#### 2-3. Guidelines for sewer system layout.

The development of final sewer plans must await the final site plan, the completion of field surveys, and to some extent, the establishment of floor grades. However, the development of economical site plans often requires concurrent preliminary planning of the sewer system. The location of building and lateral sewers will depend not only upon topography, but also upon the type and layout of the buildings to be served. Normally, the most practical location would be along one side of the street. In other cases they may be located behind the buildings midway between streets. In still other

cases, in closely built-up areas and particularly where the street is very wide or already paved, it may be advantageous and economical to construct laterals on each side of the street. Main, trunk, and interceptor sewers will follow the most feasible route to the point of discharge. All sewers will be located outside of roadways as much as practicable, so that the number of roadway crossings will be reduced to a minimum. A sewer from one building will not be constructed under another building, or remain in service where a building is subsequently constructed over it, if any other practical location for the sewer is available. Where no other location is suitable, necessary measures will be taken to assure accessibility for future excavation and complete freedom of the sewer from superimposed building loads. The following general criteria will be used where possible to provide a layout which is practical, economical and meets hydraulic requirements:

- Follow slopes of natural topography for gravity sewers.
- Check existing maps or field surveys along prospective sewer routes to assure that adequate slopes are available.
- Avoid routing sewers through heavily wooded areas and areas which require extensive restoration after construction.
- Check subsurface investigations for groundwater levels and types of subsoil encountered. If possible, avoid areas of high groundwater and the placement of sewers below the groundwater table.
- Locate manholes at changes in direction, size or slope of gravity sewers.
- Sewer sections between manholes should be straight. The use of curved sewer alignment is not recommended.
- Manholes should be located at intersections of streets when possible.
- Avoid placing manholes where the tops will be submerged or subject to surface water inflow.
- Designer should evaluate alternative sewer routes where applicable.
- Verify that final routing selected is the most cost effective alternative that meets service requirements.

#### 2-4. Protection of water supplies.

There must be no physical connection between a potable water line and the sewer system. Sewer design will meet the following criteria:

- Sewers will be located no closer than 50 feet horizontally to water wells or earthen reservoirs to be used for potable water supply.
- Sewers will be located no closer than 10 feet horizontally to potable water lines; where the bottom of the water pipe will be at least 12 inches above the top of the sewer, the horizontal spacing may be a minimum of 6 feet.
- Sewers crossing above potable water lines must be constructed of suitable pressure pipe or fully encased in concrete for a distance of 10 feet on each side of the crossing. Pressure pipe will be

as required for force mains in TM 5-814-2/AFM 88-11, Chapter 2, and will have no joint closer horizontally than 3 feet to the crossing, unless the joint is encased in concrete. The thickness of the concrete encasement will be a minimum of 4 inches at pipe joints.

- Depressed sewers crossing potable water lines must be installed below the water line with a minimum vertical clearance of 2 feet. Sewer joints will not be closer horizontally than 3 feet to the crossing, unless the joints are fully encased in concrete as required above.

## CHAPTER 3

### HYDRAULIC DESIGN OF SEWERS

#### 3-1. Quantity of wastewater.

For any segment of proposed sewer, the design wastewater flow must be determined. Sanitary or domestic wastes based on the population served by a given segment, extraneous infiltration/inflow, and contributing industrial flows must be added to produce the design flow. Where existing flow records or data showing required flow capacity are not available, the methods and criteria discussed below will be used to develop design flows.

a. *Tributary area.* This is the area contributing wastewater to a particular sewer segment. The quantity of wastewater which is collected by a particular segment is dependent upon the types of personnel and industrial activities which are regularly found in the area. Where no information is available on existing areas to be sewered, a survey will be required to determine the number and classification of personnel and the types of industries.

b. *Sanitary or domestic wastes.*

(1) *Contributing population.* Domestic wastewater quantities normally are to be computed on a contributing population basis, except as noted in subparagraphs d and e below. The population to be used in design depends upon the type of area which the sewer serves. If the area is strictly residential, the design population is based on full occupancy of all housing and quarters served. If the area served is entirely industrial, the design population is the greatest number, military and civilian, employed in the area at any time, even though some of these persons may also be included in the design of sewers in the residential area. For sewers serving both residential and industrial areas, the design population includes residents and nonresidents, but in the design of these sewers obviously no person should be counted more than once. Allowances will be made for future population changes based on facility personnel requirements and master planning projections.

(2) *Average daily flow.* Average daily per capita wastewater quantities for different types of installations and buildings are given in table 3-1. The average daily flow will be computed by multiplying the resident and nonresident contributing populations by the appropriate per capita allowances and adding the two flows. The average daily flow represents the total waste volume generated over a 24-hour period. However, it is not a realistic indicator of the rate of flow when wastes are generated over shorter periods of 8, 10, 12 hours, etc. Thus, the average daily flow will be used only for designing sewers to serve the entire in-

stallation, or large sections of the installation, and where a major portion of the wastewater is generated by residents over a 24-hour period.

Table 3-1. Domestic Wastewater Allowances<sup>1</sup>

	Gallons/Capita/Day	
	Permanent	Field
Type of Installation <sup>2</sup>	Construction	Training
Army Posts, Forts, Camps, Airfields, Plants and Depots	100	35
Air Force Bases, Stations and Other Facilities	100	—
POW and Internment Camps	—	35
Type of Building <sup>3</sup>		
Single Family Housing (per unit) <sup>4</sup>	300	—
Multi Family Housing (per unit) <sup>4</sup>	250	—
BOQ and BEQ	70	20
EM Barracks	50	15
Hospitals (per bed) <sup>5</sup>	300-600	100

Other buildings and establishments normally found on military installations, such as bowling alleys, theaters, clubs, cafeterias, laundromats, schools, shops, gasoline service stations, etc., will be assigned typical waste loading values obtained from standard textbooks.

Notes on the use of table 3-1.

1. Allowances do not include industrial and process wastes as defined in Chapter 3 of TM 5-814-8.
2. These values represent domestic waste quantities for resident personnel averaged over the entire installation for a 24-hour period. Nonresident personnel and civilian employees working 8-hour shifts will be allowed 30 gallons/capita/day. Normally, these quantities are to be used in design of wastewater treatment facilities as indicated in Chapter 4 of TM 5-814-3/AFM 88-11, Volume 3. However, they will also be used for sizing interceptors, trunk sewers and pumping stations serving large portions of the installation.
3. For design of sewers serving smaller areas where several buildings or a group of buildings must be considered, the appropriate wastewater allowances shown in the table or obtained from standard textbooks will be used.
4. In family housing areas, each housing unit will be assigned 3.6 residents for the purpose of calculating populations.
5. No separate allowance will be made for nonpatients and employees working shifts.

(3) *Average hourly flowrate.* When designing sewers to serve small areas of the installation where several buildings or a group of buildings are under consideration, and where the majority of wastewater is generated by nonresidents or other short term occupants, the average hourly flowrate will be used. The average hourly flowrate will be computed based on the actual period of waste generation. For example, 1000 nonresidents at 30 gpcd would generate 30,000 gallons in 8 hours for an average hourly flowrate of 3750 gph (90,000 gpd). Note that the average daily flow would still be 30,000 gpd, or 30,000 gallons in 24 hours, but the sewer must be designed hydraulically to carry the

30,000 gallons in 8 hours, not 24 hours.

(4) *Peak diurnal flowrate.* The normal daily range of the rate of flow, or the diurnal pattern, is from approximately 40 percent to 250 percent of the average daily flow. The peak daily or diurnal flowrate is an important factor in sewer design, especially when minimum velocities are to be provided on a daily basis. The peak diurnal flowrate will be taken as one half of the extreme peak flowrate.

(5) *Extreme peak flowrate.* Extreme peak rates of flow occur occasionally and must be considered. Sewers will be designed with adequate capacity to handle these extreme peaks flowrates. Ratios of extreme peak flowrates at average flows will be calculated with the use of the following formula:

$$R = \frac{C}{Q^{0.167}}$$

where:

R = ratio of extreme peak flowrate to average flow

Q = average daily flow or average hourly flowrate in million gallons per day, gallons per day, or gallons per hour, and

C = constant, 3.8 for mgd, 38.2 for gpd or 22.5 for gph

When designing sewers to serve the entire installation, or large areas of the installation, and where a major portion of the wastewater is generated by residents over a 24-hour period, the average daily flow will be used in the formula, and the extreme peak flowrate will be computed by multiplying the average daily flow by the ratio R. However, for sewers serving small areas of the installation where several buildings or a group of buildings are being considered, and where the majority of wastewater is generated by nonresidents or other short term occupants, the average hourly flowrate will be used in the formula, and the extreme peak flowrate will be computed by multiplying the average hourly flowrate by the ratio R. Examples illustrating the use of the above formula are provided in Appendix B.

c. *Infiltration and inflow.* Extraneous flows from groundwater infiltration enter the sewer system through defective pipe, joints, fittings and manhole walls. Sources of inflow include connections from roof leaders, yard drains, storm sewers, cooling water discharges and foundation drains, in addition to submerged manhole covers.

(1) In computing wastewater flows for new sewers, design allowances for groundwater infiltration will be 500 to 1000 gallons/day per inch diameter per mile of pipe, and will be added to the peak rate of flow. For design of Air Force facilities, use 500 gpd/in/mi. Acceptance tests required for newly constructed sewers normally limit leakage to 500 gpd/in/mi.

(2) Where infiltration/inflow must be calculated from an existing collection system, attempts must be

made to obtain flow records from treatment facilities or pumping stations which will provide information on the magnitude of I/I quantities. In the absence of such flow data, and depending on the scope of the project, it may be necessary to measure flows in the existing system. Where this is not possible or feasible, allowances of 10,000 to 100,000 gpd/mile of pipe may be used depending on the size and age of the sewers, materials of construction, and the soil and ground-water conditions. Installation personnel will usually have some knowledge of these matters and should be aware of major problems. Where I/I is known to be excessive, it should be determined prior to design if corrective measures are planned for the existing system, or if U.S. Environmental Protection Agency (EPA) evaluation and rehabilitation programs will be implemented.

d. *Industrial waste flows.* Industrial waste quantities from ordnance plants, technical laboratories, laundries, vehicle maintenance shops, airplane wash racks, plating shops, and such industries cannot be computed totally on a population or fixture unit basis. Flows from such plants depend upon the type and extent of the activities. Industrial waste sewers and sanitary sewers will be designed for the peak industrial flow as determined for the particular industrial process or activity involved.

e. *Fixture unit flow.* The size of building connections, including those from theaters, cafeterias, clubs, quarters, and other such buildings, will in all cases be large enough to discharge the flow computed on a fixture unit basis as set forth in the manual on plumbing, TM 5-810-5/AFM 88-8, Chapter 4. This requirement applies to building connections only, and not to the lateral or other sewers to which they connect.

### 3-2. Gravity sewer design.

Sewers will be designed to discharge the wastewater flows as required by paragraph 3-1. Generally, it is not desirable to design sewers for full flow, even at peak rates. Flows above 90 to 95 percent of full depth are considered unstable, and may result in a sudden loss of carrying capacity with surcharging at manholes. In addition, large trunk and interceptor sewers laid on flat slopes are less subject to wide fluctuations in flow, and if designed to flow full may lack sufficient air space above the liquid to assure proper ventilation. Adequate sewer ventilation is a desirable method of preventing the accumulation of explosive, corrosive or odorous gases, and of reducing the generation of hydrogen sulfide. Therefore, trunk and interceptor sewers will be designed to flow at depths not exceeding 90 percent of full depth; laterals and main sewers, 80 percent; and building connections, 70 percent. However, regardless of flow and depth the minimum sizes to be used are 6-inch for building connections and 8-inch for all other sewers. The following formula,

charts, procedures and criteria will be used for design.

a. *Design formula and charts.* The Manning formula will be used for design of gravity flow sewers as follows:

$$V = \frac{1.486}{n} R^{2/3} S^{1/2}$$

where:

V = velocity in feet per second

n = coefficient of pipe roughness

R = hydraulic radius in feet, and

S = slope of energy line in feet per foot

(1) *Roughness coefficient.* Values of n to be used in the formula range from 0.013 to 0.015. The lowest n values apply to new or relatively new pipe (in sections greater than 5 feet) with smooth interior surfaces, smooth bore, even joints, in excellent to good condition and well constructed. Higher n values are required for older pipe with rough interior surfaces, open or protruding joints, in fair to bad condition and poorly constructed. Values up to 0.017 are often justified for very old pipe (such as brick or block sewers) in extreme deterioration, or pipe very poorly constructed with improper alignment, sags and bellies, cracked or offset joints, broken wall sections or internal corrosion. Some manufacturers of plastic and asbestos cement pipe report n values of 0.009 to 0.011. However, due to uncertainties in design and construction, plus a desire to provide a margin of safety, n values smaller than 0.013 will not normally be permitted. Variation of n with depth of flow has been shown experimentally, and may be considered in designing sewers to flow partially full. A solution to the Manning formula for full pipe flow is shown in figure 3-1, which will be used in conjunction with figure 3-2 for sewers flowing partially full.

(2) *Velocity.* Sewers will be designed to provide a minimum velocity of 2.0 feet per second at the average daily flow, or average hourly flowrate, and a minimum velocity of 2.5 to 3.5 fps at the peak diurnal flowrate, as determined in paragraph 3-1. When velocities drop below 1.0 fps during periods of low flow, organic solids suspended in the wastewater can be expected to settle out in the sewer. Sufficient velocity (2.5 to 3.5 fps) must be developed regularly, once or twice daily as a minimum, to resuspend and flush out solids which may have been deposited during low flows. A velocity of 2.5 fps minimum is required to keep grit and sand suspended. However, new sewers which are properly designed and constructed should contain only minor quantities of grit or sand. Maximum velocity is set at 10.0 fps in the event that grit becomes a problem.

(3) *Slope.* Assuming uniform flow, the value of S in the Manning formula is equivalent to the sewer invert slope. Pipe slopes must be sufficient to provide the required minimum velocities and depths of cover

on the pipe. Although it is desirable to install large trunk and interceptor sewers on flat slopes to reduce excavation and construction costs, the resulting low velocities may deposit objectionable solids in the pipe creating a buildup of hydrogen sulfide, and thus will be avoided.

(a) Adequate cover must be provided for frost protection. Generally, a minimum 2 feet of earth will be required to protect the sewer against freezing. Where frost penetrates to a considerably greater depth and lasts for an appreciable length of time, the wastes may not contain sufficient heat to prevent the gradual cooling of surrounding earth and buildup of an ice film inside the pipe. Under these conditions, greater cover will be required.

(b) Sufficient cover must also be provided to protect the pipe against structural damage due to superimposed surface loadings. Concentrated and uniformly distributed loads are discussed in Chapter 5.

b. *Design procedure.* After a preliminary layout has been made, a tabulation will be prepared in convenient form setting forth the following information for each sewer section:

- Designation of manholes by numerals or letters.
- Contributing populations—resident and nonresident.
- Design flows—average, daily peak, and extreme peak.
- Length of sewer.
- Invert elevations.
- Invert slope or gradient.
- Pipe diameter and roughness coefficient.
- Flow depths at design flows.
- Velocities at design flows.
- Depths of cover on the pipe—maximum and minimum.

c. *Hydraulic profile.* In most situations where small to medium sized gravity sewers are installed in long runs, it will be safe to assume uniform flow throughout the entire length of conduit. However, in cases where larger sewers, 24-inch diameter and above, are constructed in runs of less than 100 feet, and with a number of control sections where nonuniform flow may occur, a plot of the hydraulic profile is recommended. For process and plant piping at wastewater treatment facilities, a hydraulic profile is always required. Methods used to calculate and plot hydraulic profiles including backwater curves, drawdown curves and hydraulic jumps, will conform to those presented in standard hydraulics textbooks.

d. *Critical flow.* Gravity sewers will ordinarily be designed to maintain subcritical flow conditions in the pipe throughout the normal range of design flows. However, there are exceptions in which supercritical flow may be required, and will be justified. Minimum sized sewers (6- and 8-inch) designed to discharge

very low flows, must occasionally be placed on slopes steeper than critical in order to provide minimum velocities. In addition, small to medium sized sewers when required to discharge unusually large flows, may necessitate supercritical slopes. Finally, steep slopes may be unavoidable due to natural topography and

ground conditions. Where supercritical flow will occur, care must be taken in the design to insure that downstream pipe conditions do not induce a hydraulic jump or other flow disturbance. Depths of flow within 10 to 15 percent of critical are likely to be unstable, and will be avoided where pipes will flow from 50 to

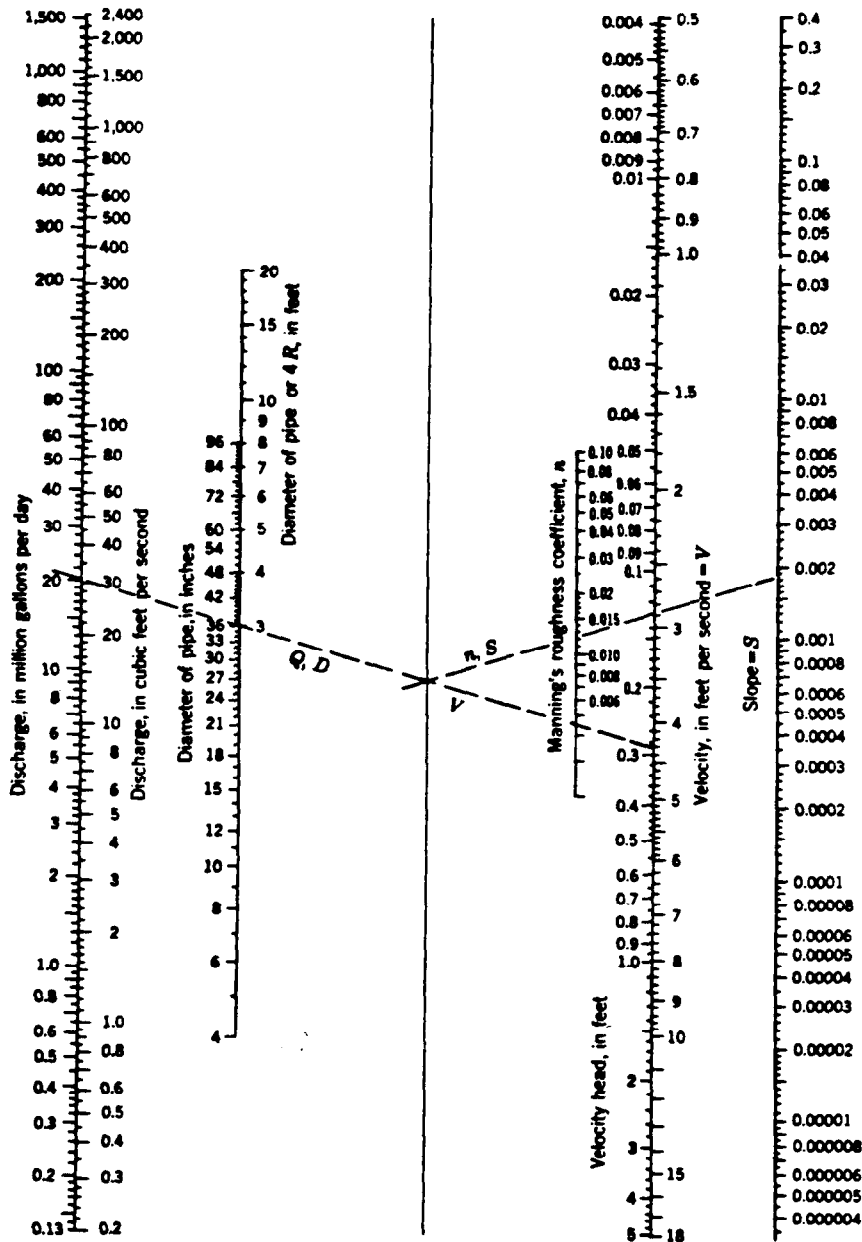

Source: Design and Construction of Sanitary and Storm Sewers - WPCF Manual of Practice No. 9 by Water Pollution Control Federation, 1970, p. 81.

Figure 3-1. Chart for Manning formula.

90 percent full. Critical depths for various flows and pipe diameters can be obtained from standard hydraulics textbooks.

**3-3. Depressed sewers.**

a. *Velocity and flow analysis.* Since a depressed sewer, or inverted siphon, is installed below the hydraulic grade line, the pipe will always be full of wastewater under pressure, even though there may be little or no flow. Thus, the design requires special care to secure velocities that will prevent clogging due to sedimentation of solids. The velocity should be as high as practicable, with a minimum requirement set at 3.0 feet per second. Hydraulic calculations may be based on the Manning formula or Hazen-Williams analysis.

A minimum Manning roughness coefficient of 0.015 is recommended due to possible accumulations of grease and other materials on pipe walls. Procedures using Hazen-Williams design for pressure pipe flow are given in TM 5-814-2/AFM 88-11, Chapter 2. The pipe will be as small as the available head permits except that pipe smaller than 6-inch is not permitted. Inasmuch as the sewer must be of sufficient size to discharge the extreme peak flows, better velocities for the normal range of flows can often be obtained by using several small pipes instead of one large pipe. This requires an entrance box equipped with a diversion gate for the periodic alternation of pipes in service and with an overflow weir so arranged that, when the flow exceeds the capacity of one pipe, the excess can over-

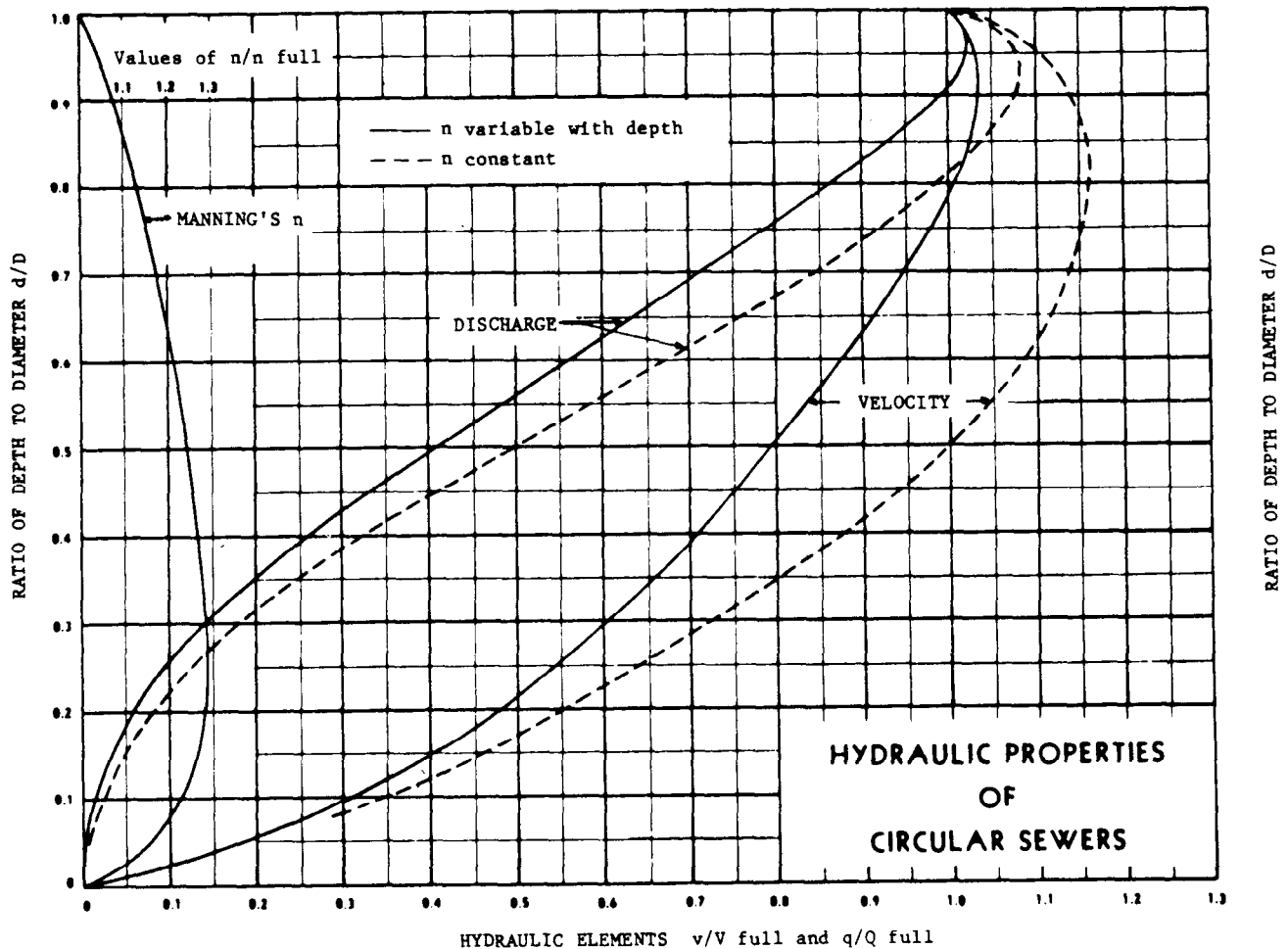

Source: Clay Pipe Engineering Manual by National Clay Pipe Institute, July 1982, p. 25.

Figure 3-2. Hydraulic properties of circular sewers.

flow to the other pipes. However, conditions might be such that two or three pipes in lieu of one would not be advantageous or necessary. Each case will be analyzed individually.

*b. Cleaning and inspection.* Depressed sewers should be flushed frequently and inspected to make sure that obstructions are removed. Therefore, manhole structures or cleanout chambers will be required at each end of the sewer to allow access for rodding and pumping.

*c. Pipe materials.* Since a depressed sewer must withstand internal pressures greater than atmospheric, pipe materials required for use will be as indicated in TM 5-814-2/AFM 88-11, Chapter 2 for force mains.

### **3-4. Hydrogen sulfide in sewers.**

Two of the most important problems occurring in wastewater collection systems are (1) the corrosion of sewers and appurtenances, and (2) the propagation and emission of odorous and toxic gases. Both of these problems can be attributed in large part to the generation of hydrogen sulfide ( $H_{2S}$ ) in sewers. Reference is made to U.S. Environmental Protection Agency (EPA) publication, Process Design Manual for Sulfide Control in Sanitary Sewerage Systems, for a complete discussion of this topic. Sewers will be designed hydraulically in accordance with EPA guidelines established therein to prevent excessive generation of  $H_{2S}$ . In general, small diameter sewers designed to maintain

velocities greater than 2.0 feet per second, and sufficient air-to-wastewater contact, normally experience no significant buildup of  $H_{2S}$ . Larger sized sewers may be susceptible to  $H_{2S}$  formation, but rates of generation can be reduced through proper design, with concentrations limited to less than 1.0 milligram per liter.

*a. Corrosion control.* Where it is determined that the potential exists for damaging  $H_{2S}$  concentrations, such as new sewer connections to older systems with a history of  $H_{2S}$  problems and deteriorating sewers, pipe materials must be selected to resist attack from sulfuric acid. Chapter 6 describes various pipe materials and applications suitable for sewer use. As indicated, the pure plastics (PVC and ABS), fiberglass, and vitrified clay are best suited for corrosive environments, whereas concrete (including ABS composite), asbestos-cement, ductile iron, and cast iron soil pipe should be avoided unless special protective linings, coatings, or treatments are provided.

*b. Sewer gases.* In designing the sewer system, consideration will be given to the possibility of objectionable odors being emitted from manholes and sewers. As noted in paragraph a. above, new sewer connections to older systems with a history of  $H_{2S}$  problems will very likely experience similar difficulties. In these cases, sewers and manholes will be located such that emissions of odorous sewer gases, and in particular  $H_{2S}$ , do not create a nuisance or hazard for nearby building occupants.

## CHAPTER 4

### SEWER SYSTEM APPURTENANCES

#### 4-1. Manholes.

*a. Requirement.* Manholes are required at junctions of gravity sewers and at each change in pipe direction, size or slope, except as noted hereinafter for building connections.

*b. Spacing.* The distance between manholes must not exceed 400 feet in sewers of less than 18-inches in diameter. For sewers 18-inch in diameter and larger, and for outfalls from wastewater treatment facilities, a spacing of up to 600 feet is allowed provided the velocity is sufficient to prevent sedimentation of solids.

*c. Pipe connections.* The crown of the outlet pipe from a manhole will be on line with or below the crown of the inlet pipe. Where conditions are such as to produce unusual turbulence in the manhole, and especially where the size of the outlet pipe is to be smaller than the inlet pipe because of the availability of a more favorable slope, it may be necessary to provide an invert drop to allow for entry head, or increased velocity head, or both. Where the invert of the inlet pipe would be more than 18-inches above the manhole floor, a drop connection will be provided.

*d. Frames and covers.* Manhole top elevations will be set to avoid submergence of the cover by surface water runoff and ponding. Where this is not possible, watertight covers will be installed to prevent storm water inflow. Bolting or locking devices will be included on covers to prevent unauthorized entry in areas designated by the using agency as secure. Frames and covers must be sufficient to withstand impact from wheel loads where subject to vehicular traffic.

*e. Design standards.* Where suitable Federal, Army or Air Force standard drawings and specifications exist, they will be used for design of manhole structures, unless a special design is required. The following construction practices will be required:

- Smooth flow channels will be formed in the manhole bottom. Laying half tile through the manhole, or full pipe with the top of the pipe being broken out later, are acceptable alternatives.
- For manholes over 12 feet in depth, one vertical wall with a fixed side-rail ladder will be provided.
- Drop connections will be designed as an integral

part of the manhole wall and base.

—In areas subject to high groundwater tables, manholes will be constructed of materials resistant to groundwater infiltration.

*f. Materials of construction.* The primary construction materials to be used for manhole structures are precast concrete rings, prefabricated plastic and fiberglass units, and cast-in-place, reinforced or nonreinforced concrete. In the past, most manholes were built of brick masonry, and are now frequently the source of significant volumes of groundwater infiltration. More recently in attempts to alleviate this problem, precast concrete, plastic, and fiberglass manholes have been utilized. In certain situations precast units will not be suitable, and cast-in-place reinforced concrete will be required. Cast-in-place construction permits greater flexibility in the configuration of elements, and by varying reinforcing the strength of similar sized structures can be adjusted to meet requirements. In general, materials used should be compatible with local construction resources, labor experience, and should be cost competitive.

#### 4-2. Building connections.

Building connections will be planned to eliminate as many bends as practical and provide convenience in rodding. Bends greater than 45 degrees made with one fitting should be avoided; combinations of elbows such as 45-45 or 30-60 degrees should be used with a cleanout provided. Generally, connections to other sewers will be made directly to the pipe with standard fittings rather than through manholes. However, a manhole must be used if the connection is more than 100 feet from the building cleanout. Normally, the cleanout inside the building will not be adequate for complete rodding, thus outside cleanouts will be provided. Manholes will be installed where cleanouts are not feasible.

#### 4-3. Cleanouts.

Cleanouts must be installed on all sewer building connections to provide a means for inserting cleaning rods into the underground pipe. An acceptable cleanout will consist of an upturned pipe terminating at, or slightly above, final grade with a plug or cap. Preferably the cleanout pipe will be of the same diameter as the building sewer, and never smaller than 6 inches.

## CHAPTER 5

### STRUCTURAL DESIGN OF SEWERS

#### 5-1. General.

The structural design of a sewer requires that the supporting strength of the pipe as installed, must equal or exceed the external loading multiplied by a factor of safety. The following criteria for structural design of sewers are based on the assumption that sewers will be laid in open trenches entirely below natural ground surface and backfilled with suitable materials, that the sides of the trench will be nearly vertical below the top of the pipe and will have slopes no flatter than one horizontal to two vertical above the pipe, and that the trench width at the top of the pipe will be relatively narrow. In general, the trench width will be limited to the maximum allowed or recommended by the pipe manufacturer. Special cases involving sewer installation in unsatisfactory soil, rock, embankments or fills, sewers requiring jacking, boring or tunneling, and pipe placed above ground, are too rare to warrant lengthy consideration in this manual. Paragraph 5-4 contains a general discussion of such situations. Sewers installed in cold regions or in seismic zones will require special design considerations.

#### 5-2. Loads on sewers.

There are three kinds of external loads to which a sewer laid in a trench may be subjected. They are (1) loads due to trench filling materials, (2) uniformly distributed surface loads, such as stockpiled materials or loose fill, and (3) concentrated surface loads, such as those from truck wheels.

*a. Trench fill loads.* The Marston formula will be used for calculating loads on rigid conduits as follows:

$$W_t = C_t w B_t^2$$

where:

$W_t$  = vertical load on conduit in pounds per lineal foot

$C_t$  = trench load coefficient for buried conduits

$w$  = unit weight of trench fill materials in pounds per cubic foot, and

$B_t$  = horizontal width of trench at top of pipe in feet

For calculation of loads on flexible conduits the prism formula will be used as follows:

$$W_t = Hw B_c$$

where:

$H$  = height of fill from top of pipe to ground surface in feet,  
and

$B_c$  = horizontal width or outside diameter of pipe in feet

The unit weight of soil backfill normally varies from a minimum of 100 to a maximum of 135 pounds per cubic foot. In the absence of soil density measurements, the weight per cubic foot of various materials may be taken as 120 pounds for mixed sand and gravel, 110 pounds for saturated top soil (loam and silt), 120 pounds for ordinary damp clay, and 130 pounds for saturated clay. The load coefficient  $C_t$  is a function of the fill height  $H$  divided by the width of trench  $B_t$ , and will be determined from figure 5-1. An examination of the Marston formula will show the importance of the trench being as narrow as practicable at and below the top of the pipe.

*b. Uniformly distributed loads.* Newmark's modification to the classical Boussinesq equation results in the following formula to be used for calculating distributed loads on rigid and flexible conduits.

$$W_d = C_s p F B_c$$

where:

$W_d$  = vertical load on the conduit in pounds per lineal foot

$C_s$  = surface load coefficient for buried conduits

$p$  = intensity of distributed load in pounds per square foot

$F$  = impact factor, and

$B_c$  = horizontal width or outside diameter of pipe in feet

The load coefficient  $C_s$  is dependent upon the area over which the load  $p$  acts. It will be selected from table 5-1 as a function of the area width  $D$  and length  $M$ , each divided by twice the height of fill  $H$ . The impact factor  $F$  will be determined with the use of the table 5-2.

*c. Concentrated loads.* The formula to be used for calculating concentrated loads on rigid and flexible conduits is a modified form of the Boussinesq equation developed by Holl, and is as follows:

$$W_c = C_s P F / L$$

where:

$W_c$  = vertical load on the conduit in pounds per lineal foot

$C_s$  = surface load coefficient for buried conduits

$p$  = concentrated load in pounds

$F$  = impact factor, and

$L$  = effective length of conduit in feet

An effective length of 3 feet will be used in all cases, except where pipe lengths are less than 3 feet, in which case the actual length of pipe will be used. The load coefficient  $C_s$  is a function of conduit width  $B_c$  and effective length  $L$ , each divided by twice the height of fill  $H$ . Determination of the load coefficient will be by the use of table 5-1, and impact factor  $F$  will

be selected from table 5-2. It will be noted from table 5-1 that the effect of a concentrated or distributed load diminishes rapidly as the amount of cover over the sewer increases.

**5-3. Supporting strength of sewers.**

A sewer's ability to resist external earth and superimposed loads depends not only on the pipe's inherent structural capability, but also on the method of installing the pipe in the trench, i.e., class of bedding, type of backfill materials and soil compaction effort, etc.

a. *Rigid conduit.* Pipe strength in general will be determined by the three-edge bearing test or TEBT (termed crushing strength in various pipe specifica-

tions) and is expressed in pounds per lineal foot. However, since this does not represent the actual field loading conditions, a relationship must be established between calculated load, laboratory test strength and field support strength. The definitions and terminology listed below will be used to develop this relationship. The total load calculated in paragraph 5-2 must not exceed the safe supporting strength.

—Field support strength is the maximum load in pounds per lineal foot which the pipe will support when installed under specified trench bedding and backfill conditions.

—The load factor in the ratio of the field support

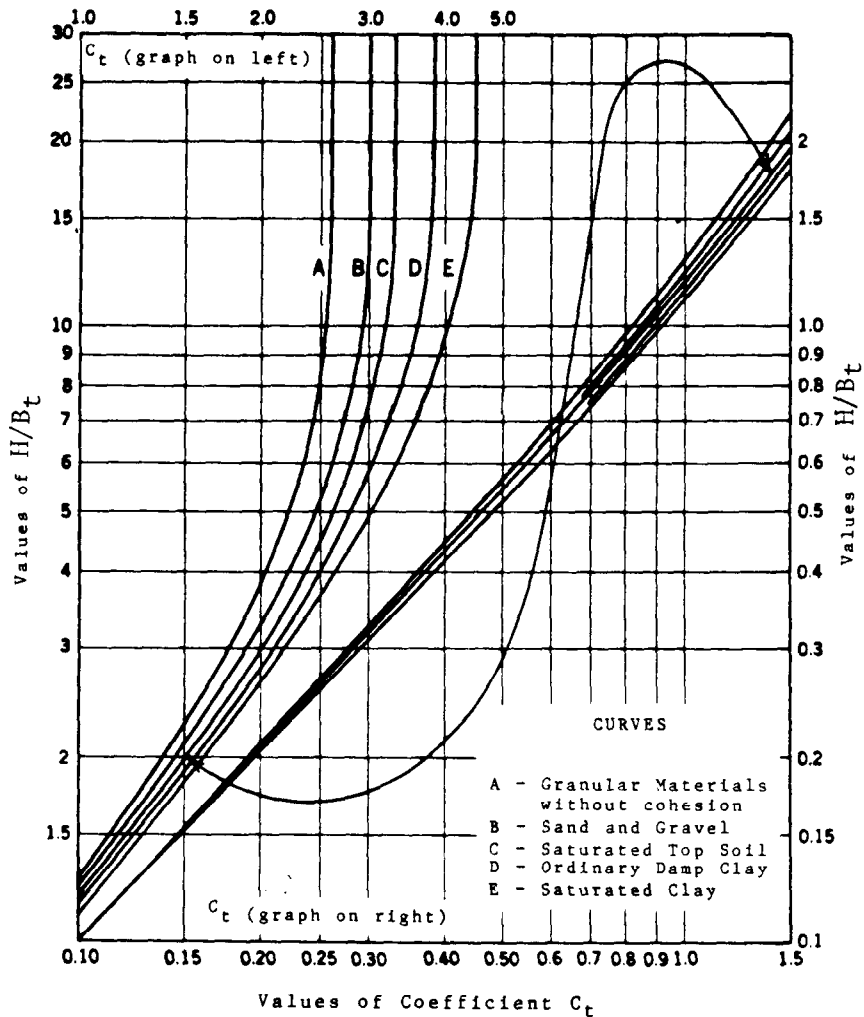

Source: Design and Construction of Sanitary and Storm Sewers - WPCF Manual of Practice No. 9 by Water Pollution Control Federation, 1970, p. 189.

Figure 5-1. Trench load coefficient.

Table 5-1. Surface load coefficient  
 Values of Load Coefficients,  $C_s$ , for Concentrated and Distributed  
 Superimposed Loads Vertically Centered Over Conduit\*

$\frac{D}{2H}$ or $\frac{B_c}{2H}$	$\frac{M}{2H}$ or $\frac{L}{2H}$													
	0.1	0.2	0.3	0.4	0.5	0.6	0.7	0.8	0.9	1.0	1.2	1.5	2.0	5.0
0.1	0.019	0.037	0.053	0.067	0.079	0.089	0.097	0.103	0.108	0.112	0.117	0.121	0.124	0.128
0.2	0.037	0.072	0.103	0.131	0.155	0.174	0.189	0.202	0.211	0.219	0.229	0.238	0.244	0.248
0.3	0.053	0.103	0.149	0.190	0.224	0.252	0.274	0.292	0.306	0.318	0.333	0.345	0.355	0.360
0.4	0.067	0.131	0.190	0.241	0.284	0.320	0.349	0.373	0.391	0.405	0.425	0.440	0.454	0.460
0.5	0.079	0.155	0.224	0.284	0.336	0.379	0.414	0.441	0.463	0.481	0.505	0.525	0.540	0.548
0.6	0.089	0.174	0.252	0.320	0.379	0.428	0.467	0.499	0.524	0.544	0.572	0.596	0.613	0.624
0.7	0.097	0.189	0.274	0.349	0.414	0.467	0.511	0.546	0.584	0.597	0.628	0.650	0.674	0.688
0.8	0.103	0.202	0.292	0.373	0.441	0.499	0.546	0.584	0.615	0.639	0.674	0.703	0.725	0.740
0.9	0.108	0.211	0.306	0.391	0.463	0.524	0.574	0.615	0.647	0.673	0.711	0.742	0.766	0.784
1.0	0.112	0.219	0.318	0.405	0.481	0.544	0.597	0.639	0.673	0.701	0.740	0.774	0.800	0.816
1.2	0.117	0.229	0.333	0.425	0.505	0.572	0.628	0.674	0.711	0.740	0.783	0.820	0.849	0.868
1.5	0.121	0.238	0.345	0.440	0.525	0.596	0.650	0.703	0.742	0.774	0.820	0.861	0.894	0.916
2.0	0.124	0.244	0.355	0.454	0.540	0.613	0.674	0.725	0.766	0.800	0.849	0.894	0.930	0.956

\*Influence coefficients for solution of Holl's and Newmark's integration of the Boussinesq equation for vertical stress.

Source: Design and Construction of Sanitary and Storm Sewers—WPCF Manual of Practice No. 9 by Water Pollution Control Federation, 1970, p. 206.

strength to the three-edge bearing test, and will be selected from figure 5-2 depending on the class of bedding used.

- Safe supporting strength is the field support strength divided by a factor of safety, equal to 1.5 for rigid conduits.
- An additional parameter is the working strength, which is the three-edge bearing strength divided by the factor of safety.

For piping not tested and rated by the TEBT method, other strength criteria will be applied as follows. Reinforced concrete pipe strength will be based on D-loads at the 0.01-inch crack load and/or ultimate load as described in the Concrete Pipe Handbook published by the American Concrete Pipe Association. For ductile iron pipe, ANSI A21.50 will be used to calculate the required pipe thickness classification in relation to field loadings. See paragraph 6-2b for additional information. The strength of cast iron soil pipe, which normally will be used for building connections only, should be evaluated as outlined in the Cast Iron Soil Pipe & Fittings Handbook published by the Cast Iron Soil Pipe Institute.

b. *Flexible conduit.* The capability to resist pipe deflection and buckling under loads is the primary criterion used in the structural design of flexible conduit. When loaded the pipe walls will deflect, thereby creating a passive soil support at the sides of the conduit. This pipe-soil system is essential in providing a high effective strength, often enabling it to out perform rigid pipe under identical loading and soil conditions.

While the three-edge bearing strength is an appropriate measure of load carrying capacity for rigid conduits, it is not applicable for describing flexible pipe stiffness. Because a flexible conduit must successfully interact with the surrounding soil to support its load, the method of backfill placement, types of materials used, soil compaction, etc., are more critical than trench width or bedding. Since the theories describing flexible pipe behavior, stiffness and deflections under load are lengthy, and the formulas cumbersome to use, they will not be presented in this manual. The methods and procedures adopted in the Handbook of PVC Pipe-Design and Construction by the UniBell Plastic Pipe Association, and WPCF Manual of Practice No. 9 will be used in design. The project specifications will be prepared to reflect the stringent installation and construction requirements for flexible pipe.

c. *Pipe installation.*

(1) *Bedding.* Figure 5-2 depicts various classes of bedding generally used when installing sewers. A complete discussion of each class is contained in several engineering publications, including WPCF Manual of Practice No. 9 and the Clay Pipe Engineering Manual by NCPI. The designer should refer to these when selecting a pipe bedding system. When the class and type of bedding have been chosen, the bedding materials will be coordinated with and identified in the specifications, and the types and sizes will be shown on the drawings.

(2) *Backfill and compaction.* Backfill materials and compaction requirements will be included in the

Table 5-2. Impact factor (F) vs. height of cover  
Installation Surface Condition

Height of Cover, ft.	Highways	Railways	Runways	Taxiways, Aprons, Hardstands, Run-up Pads
0 to 1	1.50	1.75	1.00	1.50
1 to 2	1.35	*	1.00	**
2 to 3	1.15	*	1.00	**
Over 3'	1.00	*	1.00	**

\*Refer to data available from American Railway Engineering Association (AREA)

\*\*Refer to data available from Federal Aviation Administration (FAA)

Note that for a static load, F = 1.0

Source: Handbook of PVC Pipe-Design and Construction by Uni-Bell Plastic Pipe Association, Dallas, Texas, Copyright 1977, 1979, p. 133.

specifications. The possible use of locally available materials for backfill will be investigated. Compaction requirements will be designated for the particular soil and moisture content at the site.

(3) Installation manuals for the particular types of pipe to be specified will be reviewed to ascertain that bedding, backfill and compaction are adequate for the existing subsurface conditions at the site.

#### 5-4. Special designs.

a. *Unsatisfactory soil conditions.* Information on subsurface conditions must be obtained from borings, drill holes, or test pits prior to design of the sewer system. Soil considered too unstable for use as pipe bedding or backfill consists of silt, quicksand, peat bog, muck and other organic materials. Where these materials exist, the following procedures will be used to provide a suitable pipe bedding.

(1) In situations where unstable materials occur at shallow depths, it will generally be acceptable to over-excavate native soil to just below the trench bottom, and replace with a layer of crushed stone, gravel or other coarse aggregate. Concrete or wooden cradles can be used in lieu of aggregates.

(2) Where unstable soil extends to considerable depths, more stringent measures must be taken. The sewer will be fully encased in concrete and supported on piles at each end. The pipe and encasement will be designed to act as a beam when the span distance is relatively short.

(3) For extremely severe cases, where unsatisfactory material covers a large area, and extends well below the trench bottom, a row of piling capped with concrete or wood cradles will be required to support the sewer. Dwarf piling may be suitable substitute for conventional piling in certain situations.

b. *Installation in rock.* Where sewers must be constructed in rocky terrain, trenches will be sufficiently wide to provide clearance between the sides and bottom of the pipe, and any rock in the trench. Pipe must be installed to avoid all contact with rock, or any other unyielding material in the trench. A granular type bedding or concrete cradle will normally be provided along the pipe bottom, and trenches will be backfilled

with satisfactory materials.

c. *Sewers in embankments.* The need to install sewers above original ground surface in an embankment or fill does not arise frequently at military installations. Occasionally, an embankment will be required in low lying areas to raise the grade, or will be provided to avoid placing sewers aboveground, as discussed below.

d. *Aboveground sewers.* Sewers are normally laid underground, and at sufficient depths to be protected from impact and freezing. However, in cases where valleys, watercourses, structures, or other obstacles must be crossed, it is sometimes more advantageous to install sewers aboveground. Sewers supported from bridges, piers, suspension cables, or pipe beams, ec., will be designed with adequate structural capability. Protection against freezing and prevention of leakage are important design considerations. Expansion jointing may also be required.

e. *Jacking, boring and tunneling.* In situations where sewers must be constructed more than 15 to 20 feet below ground surface, through embankments, under railroads, primary access roads, or airfield pavements, or where the facility Engineer determines that surface conditions make it difficult or impractical to excavate open trenches, it will be necessary to install the pipe by other methods. In these cases, pipe may be pushed, jacked, bored or tunneled into place. A casing pipe will normally be required for sewers installed using these methods, and will always be required to protect sewers under railroads, primary access roads and airfield pavements. The void space between the sewer pipe and casing will be filled with special aggregates capable of being blown into place, or with commercially available polyethylene or other type spacers, saddles and seals. Depending on soil resistance, rigid extra strength pipe can be forced underground by machine for distances of 50 to 150 feet. Commercially available machines used hydraulic power to produce forces ranging from 6500 to 150,000 pounds. Horizontal boring (augering) and reaming machines placed in excavated pits simultaneously remove material and hydraulically jack extra strength pipe through the ground in sizes up to 3 feet in diameter.

## CHAPTER 6

### SEWER PIPE MATERIALS, FITTINGS AND JOINTS

#### 6-1. General.

Factors which will be considered in the selection of sewer pipe materials and piping systems are:

- Flow characteristics or friction coefficient.
- Life expectancy and history of use.
- Resistance to scour and abrasion.
- Resistance to acids, alkalis, high temperature or corrosive wastes, and corrosive soils.
- Ease of handling and installation.
- Physical strength.
- Joint watertightness and ease of installation.
- Availability of pipe in required sizes, strengths, etc.
- Availability of fittings, connections and adapters.

No pipe manufactured is suitable for all sewer installation requirements and conditions. The pipe materials covered in this chapter are the ones most often used for sanitary and industrial waste sewers. Each type of pipe will be evaluated to determine its suitability for the particular design. Where iron or concrete pipe are to be considered, special attention will be paid to sub-surface and soil conditions. The characteristics of the soil in which a pipe is placed affect the rates of corrosion, with the most corrosive soils being those having poor aeration and high values of acidity, electrical conductivity, dissolved salts, and moisture content. The relative potential for corrosion may be estimated by evaluating the degree of corrosion of existing metallic or concrete pipelines previously buried in the soil. Facility engineer personnel will normally have knowledge of these matters and should be consulted. When this information is not available, or is non-conclusive, resistivity tests of the soil will be conducted and results evaluated as required in TM 5-811-4 or AFM 88-45. Pipe materials found inappropriate for use will be deleted from the project specifications. For Air Force facilities, standard ASTM or AWWA pipe specifications for the various pipe materials set forth below can be found in AFM 88-15.

#### 6-2. Ductile iron.

*a.* Ductile iron (D.I.) pipe is utilized for sewers requiring a high resistance to external loading, a high degree of toughness and ductility. It is well suited for most sanitary sewers including river crossings, piping at wastewater treatment facilities, pipe located in unstable soils, highway and rail crossings, water line crossings, depressed sewers and piping aboveground. However, the use of D.I. pipe is limited somewhat by a susceptibility to corrosion from wastewaters containing acids, and from aggressive soils. D.I. pipe will nor-

mally be cement lined, and can be provided with a bituminous coating inside or a polyethylene lining. Exterior bituminous coatings are standard, and where soil is extremely corrosive, a polyethylene encasement may be required.

*b.* Pipe is available in diameters 3-inch through 54-inch, and in 18- or 20-foot laying lengths. Allowable trench and superimposed surface loads for D.I. pipe are computed and tabulated in ANSI A21.50. The ordinary range of loadings can be met without special bedding materials and procedures. The Handbook of Ductile Iron Pipe, Cast Iron Pipe published by the Cast Iron Pipe Research Association (CIPRA) will be referenced for guidance in designing and installing ductile iron pipe.

#### 6-3. Cast iron soil.

*a.* Cast iron soil (C.I.S.) pipe will normally be allowed only as an option for building connections. C.I.S. pipe is used primarily for building interior drainage, waste and vent piping, as described in Chapter 1 of the Cast Iron Soil Pipe & Fittings Handbook published by the Cast Iron Soil Pipe Institute. C.I.S. pipe is resistant to internal and external corrosion when provided with a bituminous coating, and is not subject to abrasion from grit, sand or gravel.

*b.* C.I.S. pipe is available in 2-inch through 15-inch diameters, in 5 and 10 foot laying lengths, and is manufactured in service (SV) and extra heavy (XH) classifications. Pipe joints will be either compression type using rubber gaskets, or bell and spigot type calked with lead and oakum. Structural design of C.I.S. pipe will be in accordance with the methods outlined in Chapter 5 of the Cast Iron Soil Pipe & Fittings Handbook, with special emphasis given to external loadings and pipe strength.

#### 6-4. Vitrified clay.

*a.* Vitrified clay (V.C.) pipe is manufactured from clay and shale products to form an ideal material for sewer use. V.C. pipe has a high resistance to corrosion from acids and alkalies, and resists scouring and erosion well. This provides a distinct advantage in serving as industrial waste sewers, or sanitary sewers subject to hydrogen sulfide generation. It should be noted that availability of some sizes and strength classifications is limited in certain geographical areas. V.C. pipe is also known for brittleness.

*b.* Clay pipe is available in nominal diameters 4-inch through 42-inch, and laying lengths of 1 to 10 feet. Clay pipe is manufactured in Standard and Extra

Strength classifications. The Clay Pipe Engineering Manual, which is published by the National Clay Pipe Institute, provides engineering data to be used in designing clay pipe sewers.

### 6-5. Concrete.

a. Concrete sewer pipe is appropriate for applications requiring large diameter sizes or high strength characteristics. Care should be taken when specifying concrete pipe to assure that it is suitable for the environment in which it will be installed. Type II A cement, as specified in ASTM C 150, is sufficient for most installations. Type I may be used in certain situations where less than 0.1 percent soluble sulfates ( $SO_4$ ) occur in the soil, or the wastewater contains less than 150 mg/L sulfates. If the soil contains more than 0.2 percent water soluble sulfates, or the wastewater sulfate concentration exceeds 1000 mg/L, Type V cement will be required. Unlined concrete pipe is subject to scouring by wastewaters carrying grit and sand at high velocities.

b. Reinforced concrete (R.C.) pipe will be used where high external loadings are anticipated, and large diameters or tight joints are required. The advantages of R.C. pipe include a wide range of diameters, 12-inch through 108-inch, and laying lengths, 4 feet to 24 feet, which are available. A disadvantage is the lack of corrosion resistance to acids, especially critical where hydrogen sulfide is generated in substantial quantities. However, special PVC or clay liner plates, coatings of coal-tar, coal-tar epoxy, vinyl, or epoxy mortar can be applied to the pipe for corrosion protection. Non-reinforced concrete sewer pipe is generally available in diameters 4-inch through 30-inch, and in minimum laying lengths of 3 feet. Concrete pipe joints are either bell and spigot type using o-ring gaskets, or tongue and groove type made with cement mortar or bituminous mastic. Design of concrete sewers will be in accordance with the Concrete Pipe Handbook by the American Concrete Pipe Association.

### 6-6. Asbestos-cement.

a. Asbestos-cement (A.C.) pipe is made from a mixture of asbestos fibers and portland cement. A.C. pipe matches the durability of concrete pipe but weighs less, and is manufactured in a wide variety of strength classifications and laying lengths. A.C. pipe will deteriorate in a corrosive environment of hydrogen sulfide, acid wastes or aggressive soils, however some degree of protection can be provided with plastic linings. A.C. pipe material allowed for sewers will be limited to Type II as specified in ASTM C 500.

b. For gravity sewers, A.C. pipe is manufactured in numerous strength classifications. The class designation refers to the minimum three-edge bearing test strength in pounds per lineal foot of pipe. Lower

strength classes are generally available in diameters 8-inch through a maximum of 30-inch, and higher classes in diameters 10-inch through 42-inch. Laying lengths normally are 10 and 13 feet. Joints are made with couplings employing rubber ring gaskets.

### 6-7. Polyvinyl chloride (PVC) plastic.

a. PVC pipe is chemically inert to most acidic and alkaline wastes, and is totally resistant to biological attack. Since it is a nonconductor, PVC pipe is immune to nearly all types of underground corrosion caused by galvanic or electrochemical reactions, in addition to aggressive soils. Durability, light weight, a high strength-to-weight ratio, long laying lengths, watertight joints and smooth interior surfaces are characteristics which make PVC pipe an attractive alternative for use in sewer systems. Disadvantages include possible chemical instability due to long-term exposure to sunlight, excessive pipe deflection under trench loadings when installed improperly or subjected to high temperature wastes, and brittleness when exposed to very cold temperatures.

b. PVC sewer pipe is available in diameters 4-inch through 24-inch, and in laying lengths of 10 to 20 feet. Pipe dimensions comply with the standard dimension ratio (SDR) system, which means that mechanical properties are constant without regard to pipe sizes. Joints are integral bell and spigot type, and utilize elastomeric gaskets.

c. PVC pipe must be installed to provide continuous passive lateral soil support along the conduit, and the completed installation must be tested for diameter deflection. Manufacturers' design manuals, in addition to the Uni-bell Plastic Pipe Association's Handbook of PVC Pipe-Design and Construction, will be utilized in checking deflection, backfilling and trench loads. Allowable pipe deflections will be indicated in the project specifications.

### 6-8. Acrylonitrile-butadiene-styrene (ABS) plastic

a. *ABS composite plastic pipe.*

(1) ABS composite pipe consists of two concentric thermoplastic tubes integrally connected across the annulus by a truss-like bracing. The annular void space is filled with portland cement concrete, or other suitable material, to form a bond between the inner and outer tubes. ABS composite pipe is termed a "semi-rigid" pipe because it resists deflection better than most other plastics. The pipe is light in weight, and resists attack by acids, alkalies and biological growths.

(2) ABS composite pipe is available in diameters 8-inch to 15-inch, and in one laying length of 12.5 feet. ABS pipe is joined by either socket type molded fittings, which are solvent fused to the pipe, or by

means of mechanical seal couplings utilizing O-ring gaskets. The solvent welded joints minimize the possibility of poor joint construction, and greatly reduce groundwater infiltration. Manufacturers' design and installation manuals will be used for selecting pipe embedment, backfill and compaction requirements.

b. ABS solid wall plastic pipe. ABS solid wall plastic pipe is manufactured from the same compounds as composite pipe, however the pipe wall is of one solid material. The pipe is available in diameters 3-inch through 12-inch, and has the same jointing as composite pipe; however, it does not match the stiffness of composite pipe.

#### **6-9. Reinforced plastic mortar (RPMP).**

b. RPMP sewer pipe is composed of a siliceous sand aggregate reinforced with glass fibers, and embedded in a thermosetting polyester resin. RPMP pipe is ideally suited for large diameter applications, and performs extremely well in resisting pipe wall deflection and internal/external corrosion. The unique fiberglass/resin construction provides optimum protection against attack from wide range of chemically aggressive environments including hydrogen sulfide and other sewer gases, most natural soils, salt and brackish water, and galvanic or electrolytic reactions. No special coatings or cathodic protection are required. Even though RPMP pipe is officially designated a flexible conduit, its structural integrity is such that for most installations, the trench preparation and backfill requirements are considerably less than with other flex-

ible conduits, and even some rigid ones. Its other advantages include light weight and a smooth, glass-like interior surface.

b. RPMP sewer pipe is available in diameters 8-inch through 144-inch, and in laying lengths of 10, 20 and 40 feet. Joints are bell and spigot type utilizing O-ring gaskets. Manufacturer's design and installation manuals will be used for guidance in selecting appropriate trench and backfilling procedures.

#### **6-10. Special materials.**

In designing sewer systems for military industrial installations, pipe and appurtenances made of materials which are subject to attack by acids, alkalis or high temperature, highly corrosive industrial type wastewaters, will not be included in the specifications. The designer will carefully evaluate the particular wastes involved, and will indicate in the specifications the types, concentrations, and temperatures of the various waste materials to be encountered. Conditions seldom exist at military installations requiring discharge of acids, or other type wastes, in such concentrations that vitrified clay pipe would not be suitable. However, there may be situations where extremely corrosive wastes preclude the use of V.C. or other pipe materials covered in this manual. For these occasions, special pipe materials, linings, or coatings will be selected using manufacturers recommendations, and any other applicable publications. Laboratory certification of pipe or material performance may be required in cases of unusual wastes.

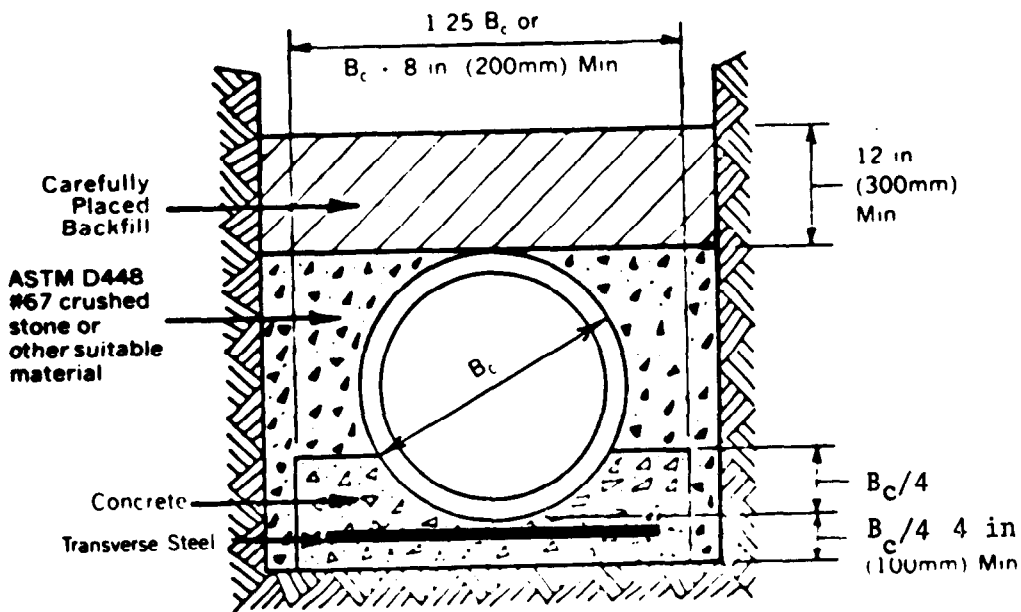

Load Factors: 2.8 Plain concrete  
 3.4 Reinforced concrete  $p=0.4\%$

$$p = \frac{\text{area of steel}}{\text{area of concrete (at invert)}}$$

(a) Class A-I

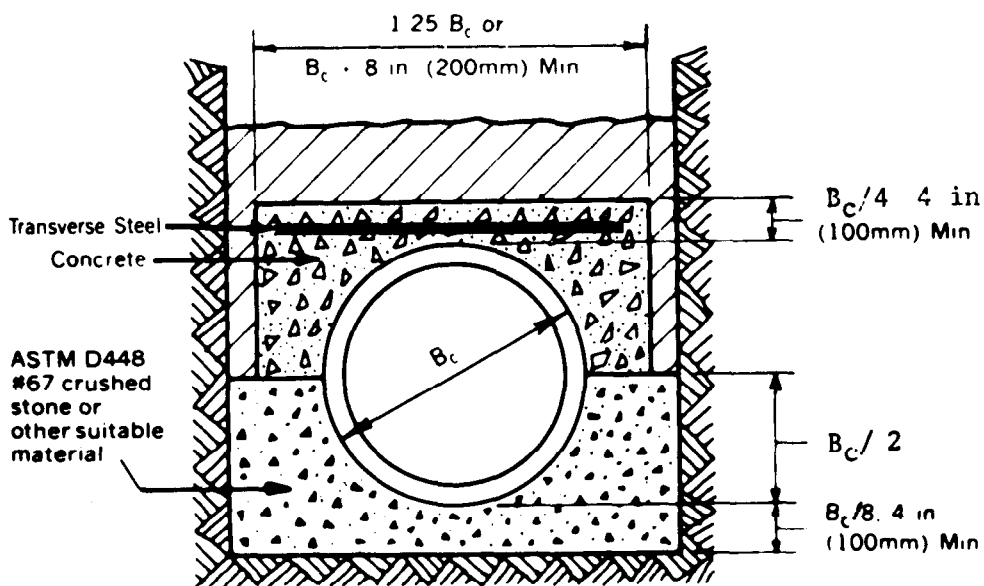

Load Factors: 3.4 Reinf. conc.,  $p = 0.4\%$   
 4.8 Reinf. conc.,  $p = 1.0\%$

(b) Class A-II

Source: Clay Pipe Engineering Manual by National Clay Pipe Institute, July 1982, p. 52

Figure 5-2. Load factors and class of bedding. (sheet 1 of 3)

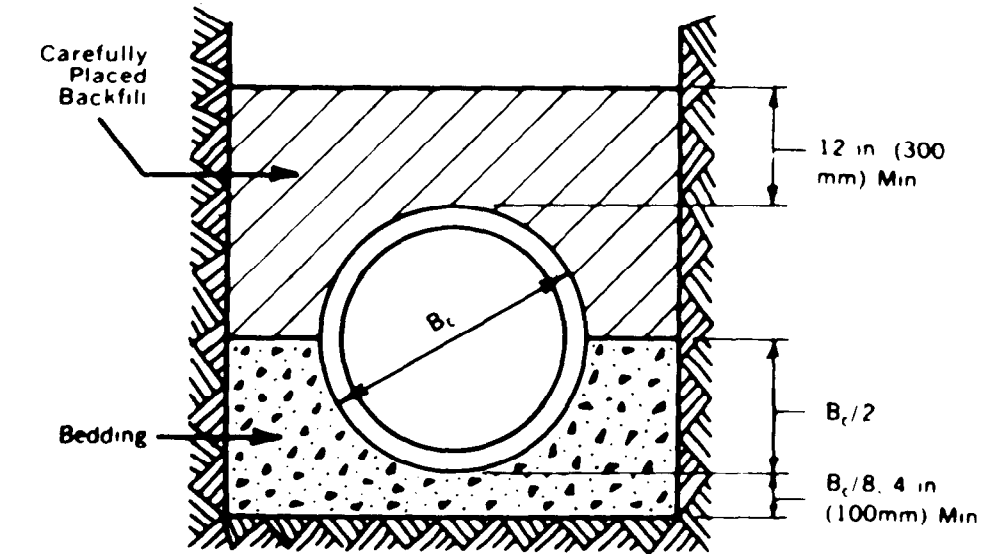

Load Factor 1.9

(c) Class B

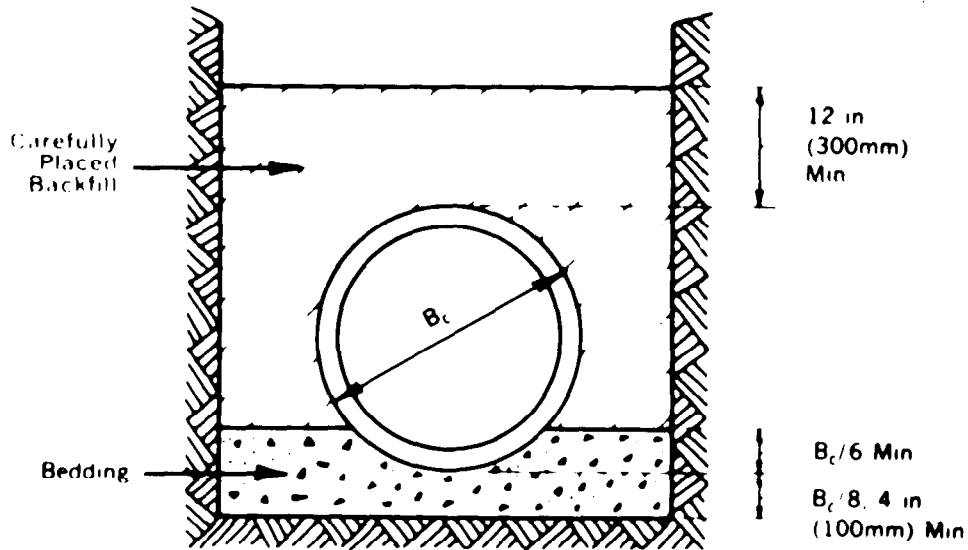

Load Factor 1.5

(d) Class C

Figure 5-2. Load factors and class of bedding. (sheet 2 of 3)

f. *Design guidance.* The methods and procedures described in WPCF Manual of Practice No. 9 for designing sewer installations in unsatisfactory soil, rock, embankments, and by tunneling, jacking, boring, etc., will be adopted. Sewer piping installed in areas subject

to earthquake damage will include seismic design as required by TM 5-809-10/AFM 88-3, Chapter 13. Cold region facilities will be designed in accordance with TM 5-852-5.

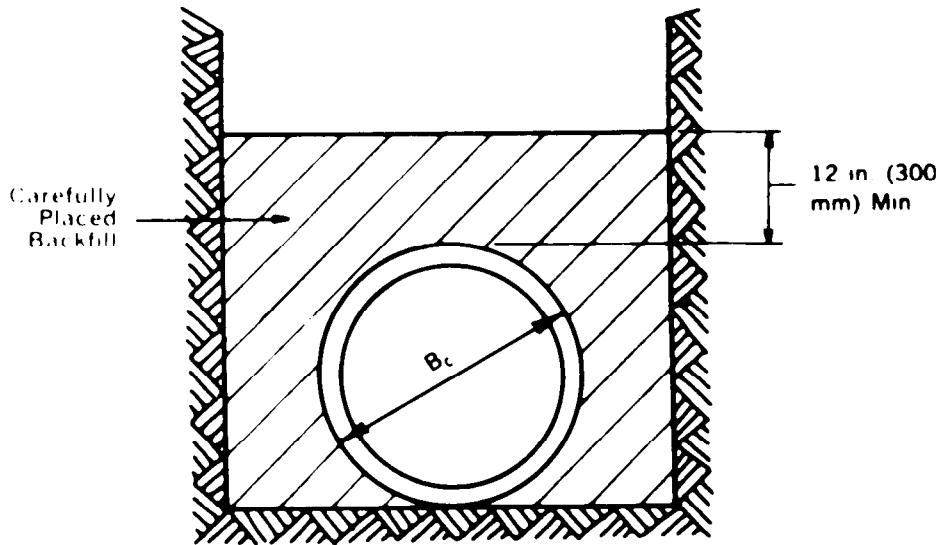

Load Factor 1.1

Flat or restored trench bottom

(e) Class D

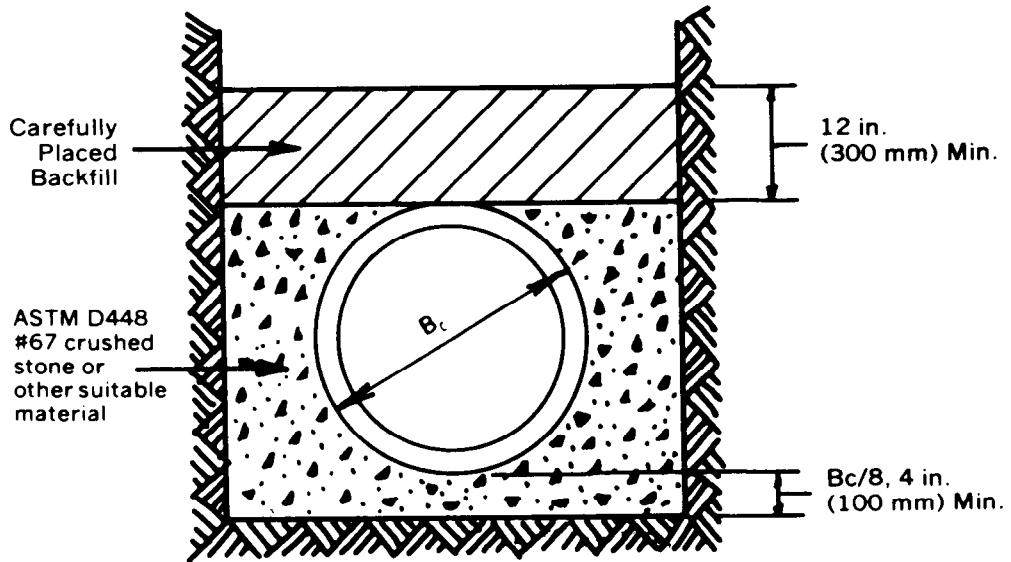

Load Factor 2.2

(f) Crushed Stone Encasement

Figure 5-2. Load factors and class of bedding. (sheet 3 of 3)

## APPENDIX A

### REFERENCES

#### A-1 Government Publications

##### a. Department of the Army and Air Force.

TM 5-809-10/ Seismic Design for  
AFM 88-3, Buildings  
Chapter 13

TM 5-810-5/AFM Plumbing  
88-8, Chapter 4

TM 5-811-4 Electrical Design:  
Corrosion Con-  
trol

TM 5-814-2/AFM Sanitary and In-  
88-11, Chapter dustrial Waste-  
2 water Collec-  
tion—Pumping  
Stations and  
Force Mains

TM 5-814-3/AFM Domestic Waste-  
88-11, Volume 3 water Treatment  
TM 5-814-8 Evaluation Cri-  
teria Guide for  
Water Pollution  
Prevention, Con-  
trol and Abate-  
ment Programs

TM 5-852-5 Arctic and Subarc-  
tic Construc-  
tion: Utilities

##### b. Department of the Air Force.

AFM 88-45 Civil Engineering  
Corrosion Con-  
trol—Cathodic  
Protection De-  
sign

AFM 88-15 Criteria and  
Standards for  
Air Force Con-  
struction

##### c. U.S. Environmental Protection Agency (EPA).

Technology Transfer Office, 26 West St.  
Clair Street, Cincinnati, OH 45268  
Process Design Manual for Sulfide Con-  
trol in Sanitary Sewerage Systems  
(1974)

#### A-2. Nongovernment Publications.

American Concrete Pipe Association,

8320 Old Court House Rd, Vienna, VA  
22180

Concrete Pipe Handbook (1981)  
American National Standards Institute  
(ANSI) Dept. 671, 1430 Broadway,  
New York, NY 10018

A 21.50—1976 Thickness Design  
of Ductile-Iron  
Pipe.

American Society of Testing Materials  
(ASTM) 1916 Race St., Philadelphia,  
PA 19103

C 150-81 Portland Cement  
C 500-79a Asbestos-Cement  
Pipe

Cast Iron Soil Pipe Institute, 1499 Chain  
Bridge Rd., McLean, VA 22101

Cast Iron Soil Pipe & Fittings Handbook  
(1976), Revised 1979

Cast Iron Pipe Research Association  
(CIPRA), 1301 West 22nd St., Oak  
Brook, IL 60521

Handbook of Ductile Iron Pipe, Cast Iron  
Pipe (1978)

National Clay Pipe Institute (NCPI), 350  
W. Terra Cotta Ave., P.O. Box 310,  
Crystal Lake, IL 60014, 14700 E. Fire-  
stone Blvd., La Mirada, CA 90638,  
1015-15th St. NW, Suite 804, Wash-  
ington, DC 20005

Clay Pipe Engineering Manual (1982)  
Uni-Bell Plastic Pipe Association, 2655  
Villa Creek Drive, Suite 150, Dallas,  
TX 75234

Handbook of PVC Pipe—Design and  
Construction (1977, 1979)

Water Pollution Control Federation  
(WPCF), 2626 Pennsylvania Avenue  
NW, Washington, DC 20037

Manual of Practice Regulation of Sew-  
er Use (1975)  
No. 3

Manual of Practice Design and Con-  
struction of  
Sanitary and  
Storm Sewers  
No. 9 (2nd ed., 1970)

## APPENDIX B

### EXAMPLE PROBLEMS

1. Design 1 mile of interceptor sewer serving a military installation with the following populations and industrial discharges.

20,000 residents living on the installation (100 gpcd—Table 3-1)

6,000 nonresidents or employees coming from off-post and working 8-hour shifts (30 gpcd—Table 3-1)

Peak industrial flowrate = 1.0 mgd

Allow for an infiltration rate of 1000 gpd/in./mi.

#### Domestic Flows

$20,000 \times 100 = 2,000,000 \text{ gpd} = 2.0 \text{ mgd}$

$6,000 \times 30 = 180,000 \text{ gpd} = 0.18 \text{ mgd}$

total average daily flow = 2.18 mgd

Use a 24-hour basis since waste load is from the entire installation, and 92 percent of total is generated by residents.

#### Extreme peak flowrate

$R = 3.8/(2.18)^{0.187} = 3.34$

$3.34 \times 2.18 = 7.28 \text{ mgd}$

Peak diurnal flowrate =  $1/2 \times 7.28 = 3.64 \text{ mgd}$

#### Infiltration Allowance

Assume a 30-inch sewer

$1000 \times 30 \times 1 = 30,000 \text{ gpd} = 0.03 \text{ mgd}$

#### Design Flows

Extreme peak =  $7.28 + 0.03 + 1.0 = 8.31 \text{ mgd}$

Peak diurnal =  $3.64 + 0.03 + 1.0 = 4.67 \text{ mgd}$

Average daily =  $2.18 + 0.03 + 1.0 = 3.21 \text{ mgd}$

#### Typical Sewer Design

Try a 30-inch sewer on a 0.10 percent slope ( $n = 0.013$ )

Flow depths and velocities

$Q = 8.31 \text{ mgd}$        $d/D = 0.80 < 0.90$  (Para. 3-2)

$V = 3.0 \text{ fps}$

$Q = 4.67 \text{ mgd}$        $d/D = 0.53$        $V =$

2.7 fps

> 2.5

fps

$Q = 3.21 \text{ mgd}$        $d/D = 0.43$        $V =$

2.5 fps

> 2.0

fps

Critical depths

$Q = 8.31 \text{ mgd}$        $dc/D = 0.48 < 0.80$

$Q = 4.67 \text{ mgd}$        $dc/D = 0.36 < 0.53$       Flows

are sub-

critical

$Q = 3.21 \text{ mgd}$        $dc/D = 0.30 < 0.43$

2. Design 2000 feet of main or trunk sewer serving a

large portion of the above installation with the following facilities.

#### Family Housing

500 units with 1800 residents ( $500 \times 3.6$  at 100 gpcd—Table 3-1)

#### Commercial Buildings

10 offices with 700 nonresidents, or employees from off-post, working 8-hour shifts (30 gpcd—Table 3-1)

#### Elementary School

500 students for 8 hours per day, 200 of the students live in the area and 300 are nonresidents (30 gpcd—Table 3-1)

#### Laundromat

50 machines—open 12 hours per day (500 gpd/machine is a typical allowance)

#### Domestic Flows

Resident  $1800 \times 100 = 180,000 \text{ gpd}$  on a 24-hour basis

Nonresident  $(700 + 300) \times 30 = 30,000 \text{ gpd}$  on an 8-hour basis

Note that the nonresident population includes office workers and students who do not live in the area.

total average daily flow = 210,000 gpd

Use a 24-hour basis since wastes are from a large area on the installation and 85 percent is generated by residents.

#### Extreme peak flowrate

$R = 38.2/(210,000)^{0.187} = 4.93$

$4.93 \times 210,000 = 1,035,300 = 1.04 \text{ mgd}$

Peak diurnal flowrate =  $1/2 \times 1.04 = 0.52 \text{ mgd}$

#### Industrial Flow

##### Laundromat

$50 \times 500 = 25,000 \text{ gpd}$  over 12 hours

Peak flowrate =  $50,000 \text{ gpd} = 0.05 \text{ mgd}$

#### Infiltration Allowance

Assume a 12-inch sewer

$1000 \times 12 \times (2000/5280) = 4545 \text{ gpd} = 0.005 \text{ mgd}$

#### Design Flows

Extreme peak =  $1.04 + 0.005 + 0.05 = 1.095 \text{ mgd}$

Diurnal peak =  $0.52 + 0.005 + 0.05 = 0.575 \text{ mgd}$

Average daily =  $0.21 + 0.005 + 0.05 = 0.265 \text{ mgd}$

#### Typical Sewer Design

Try a 12-inch sewer on a 0.35 percent slope ( $n = 0.013$ ).

Flow depths and velocities

$Q = 1.095 \text{ mgd}$        $d/D = 0.68 < 0.80$  (para. 3-2)

$V = 2.9 \text{ fps}$

Q = 0.575 mgd	d/D = 0.46	V =	> 2.5
		2.5 fps	fps
		= minimum	V =
Q = 0.265 mgd	d/D = 0.30	V =	2.0 fps
		2.0 fps	= minimum
		= minimum	

Q = 663 gph	d/D = 0.05	V =	> 2.5
		2.5 fps	fps
		= minimum	V =
		2.0 fps	= minimum
		= minimum	

Critical depths

Q = 1.095 mgd dc/D = 0.55 < 0.68  
 Q = 0.575 mgd dc/D = 0.40 < 0.46

Flows are sub-critical

Critical depths  
 Q = 4700 gph dc/D = 0.29 > 0.20\*  
 Q = 2382 gph dc/D = 0.20 > 0.13\*

\*Note that supercritical flow will result here. The critical slope equals 0.65 percent. However, a slope of 3.0 percent is required to produce the minimum velocity of 2.0 fps. Considering that the sewer is of minimum size, and that a flatter slope is not feasible if adequate velocity is to be provided, supercritical flow would be justified in this case.

3. Design 1000 feet of lateral sewer for a small tributary area on the above installation with the following flows.

Offices

2 buildings with 100 employees working 8-hour shifts (30 gpcd is a typical allowance)

Theater

300 seats—open 10 hours per day (3 gpd/seat typical allowance)

Shop

30 employees working 8-hour shifts (30 gpcd is a typical allowance)

No industrial wastes

Domestic Flows

Offices, Theater and Shop

100 × 30 = 3000 gpd over 8 hours

300 × 3 = 900 gpd over 10 hours

30 × 30 = 900 gpd over 8 hours

total average daily flow = 4800 gpd

Use an 8-hour basis since tributary area is small and all occupants are short term.

Average hourly flowrate = 4800/8 = 600 gph

Extreme peak flowrate

R = 22.5/(600)<sup>0.167</sup> = 7.73

7.73 × 600 = 4637 gph

Peak diurnal flowrate = 1/2 × 4637 = 2319 gph

Infiltration Allowance

Assume an 8-inch sewer (minimum size).

1000 × 8 × (1000/5280) = 1515 gpd = 63 gph

Design Flows

Extreme peak = 4637 + 63 = 4700 gph

Diurnal peak = 2319 + 63 = 2382 gph

Average hourly = 600 + 63 = 663 gph

Typical Sewer Design

Try an 8-inch sewer on a 3.0 percent slope (n = 0.013).

Flow depths and velocities

Q = 4700 gph d/D = 0.20

V =

3.5 fps

Q = 2382 gph d/D = 0.13

V =

2.7 fps

4. Design a short lateral sewer to serve a battalion headquarters area with 5 companies, each consisting of 100 men. Facilities include a 500 man barracks complex, administrative offices, motor pool and mess hall. During the normal 8-hour workday a total of 300 people work in the area, 100 residents (out of 500 total) plus 200 nonresiding officers, NCO's and civilian employees. No industrial wastes are generated. A per capita allowance of 50 gpd from Table 3-1 will be used for the barracks buildings, and 30 gpcd is a typical allowance for office and shop workers.

Domestic Flows

300 × 30 = 900 gpd on an 8-hour basis

500 × 50 = 25,000 gpd on a 16-hour basis

total average daily flow = 34,000 gpd

Compute average hourly flowrates

For 8 hours - 9000/8 = 1125 gph

For 16 hours - 25,000/16 = 1563 gph

Use the 1563 gph as the average hourly flowrate

Extreme peak flowrate

R = 22.5/(1563)<sup>0.167</sup> = 6.59

6.59 × 1563 = 10,300 gph

Peak diurnal flowrate = 1/2 × 10,300 = 5150 gph

Design Flows

Extreme peak = 10,300 gph

Peak diurnal = 5150 gph

Average hourly = 1563 gph

Typical Sewer Design

Try an 8-inch sewer on a 1.4 percent slope (n = 0.013)

Flow depths and velocities

Q = 10,300 gph d/D = 0.35

V =

3.3 fps

Q = 5150 gph d/D = 0.25

V =

2.8 fps

> 2.5

fps

Q = 1563 gph d/D = 0.14

V =

2.0 fps

Critical depths  
 Q = 10,300 gph  
 Q = 5150 gph

$$dc/D = 0.43 > 0.35^*$$

$$dc/D = 0.30 > 0.25^*$$

= minimum

$$Q = 1563 \text{ gph}$$

$$dc/D = 0.17 > 0.14^*$$

\*Again flow would be supercritical, but since a slope of 1.4 percent is required to produce the maximum velocity of 2.0 fps ( $S_c = 0.7$  percent), and the sewer is of minimum size, supercritical flow is justified.

## GLOSSARY

**Building Connection.** The pipe carrying wastes from the building drain to a lateral sewer. Also called building sewer or house sewer.

**Collection System.** A system of sewers and appurtenances for the collection and conveyance of sanitary and industrial wastewaters.

**Combined Sewer.** A sewer designed to carry both storm water and wastewater flows.

**Depressed Sewer. (Also Inverted Siphon).** A sewer constructed below the hydraulic grade line to pass beneath a stream, valley or structure. Pipe is always full of water under pressure.

**Force Main.** A pressurized pipeline normally on the discharge side of a wastewater pumping station.

**Gravity Sewer.** A sewer designed to carry sanitary or industrial wastes by gravity flow.

**Industrial Wastes.** Industrial or process wastes at military installations are produced by metal finishing operations, photographic processing, munitions plants, vehicle repair and maintenance depots, aircraft maintenance hangars, cooling tower and boiler blowdown, and similar facilities. Refer to TM 5-814-6 and TM 5-814-8 for descriptions and characteristics of industrial wastes.

**Industrial Waste Sewer.** A sewer in which industrial

wastes predominate.

**Interceptor Sewer.** Large sewer which intercepts a number of trunk sewers, and transports wastes to the wastewater treatment facility.

**Lateral Sewer.** A sewer which receives wastes from building connections and discharges into a main sewer. Also called branch sewer.

**Main Sewer.** A medium sized sewer to which one or more lateral (or branch) sewers are tributary.

**Outfall Sewer.** A pipeline which conveys the effluent from a wastewater treatment facility to its point of final discharge.

**Sanitary or Domestic Wastes.** Sanitary or domestic wastewaters at military installations are derived from residences, barracks, offices, schools, hospitals, administrative buildings, and other sources related to the general population served. TM 5-814-3/AFM 88-11, Volume 3 and TM 5-814-8 describe the characteristics of domestic type wastes.

**Sanitary Sewer.** A sewer which carries sanitary or domestic wastes, and to which storm, surface and ground waters are not intentionally admitted.

**Trunk Sewer.** A medium to large sized sewer which receives wastes from tributary main sewers serving a large area, and discharges into an interceptor.

**BIBLIOGRAPHY**

- Babbitt, H. E. and Bauman, E. R., *Sewerage and Sewage Treatment*, 8th ed., John Wiley and Sons, New York, 1958.
- Brater, E. F. and King, H. W., *Handbook of Hydraulics*, 6th ed., McGraw Hill, New York, 1976.
- Fair, G. M., Greyer, J. C. and Okun, D. A., *Elements of Water Supply and Wastewater Disposal*, 2nd ed., John Wiley and Sons, New York, 1971.
- Gehm, H. W. and Bregman, J. I., *Handbook of Water Resources and Pollution Control*, Van Nostrand Reinhold, New York, 1976.
- Joint Task Force of the American Society of Civil Engineers and the Water Pollution Control Federation, *Gravity Sanitary Sewer Design and Construction*, WPCF Manual of Practice No. FD-5, Washington, D.C., 1982.
- Metcalf & Eddy, Inc., *Wastewater Engineering: Collection and Pumping of Wastewater*, McGraw Hill, New York, 1981.

The proponent agency of this publication is the Office of the Chief of Engineers, United States Army. Users are invited to send comments and suggested improvements on DA Form 2028 (Recommended Changes to Publications and Blank Forms) direct to HQDA (DAEN-ECE-G), WASH DC 20314-1000.

By Order of the Secretaries of the Army and the Air Force:

Official:

DONALD J. DELANDRO  
*Brigadier General, United States Army*  
*The Adjutant General*

JOHN A. WICKHAM, JR.  
*General, United States Army*  
*Chief of Staff*

Official:

JAMES H. DELANEY  
*Colonel, United States Air Force*  
*Director of Administration*

CHARLES A. GABRIEL, *General USAF*  
*Chief of Staff*

Distribution:

Army: To be distributed in accordance with DA Form 12-34B, TM 5-800 SERIES: requirements, for Construction.

Air Force: F